



# QUICK REFERENCE SPECIFICATIONS



Q45 2000

Quick Reference

Engine

## VH41DE

Mark Actual to Confirm

Notes

**Engine Oil** SAE 10W-30 (API SG, SH & Energy Conserving II)  
 With Oil Filter 5 5/8 qt  
 Without Oil Filter 5 1/4 qt

### Tune up

#### Spark Plugs (Platinum)

Standard Type PFR5G-11  
 Hot Type PFR4G-11  
 Cold Type PFR6G-11

**Ignition Timing** 15° ± 2° BTDC

--

**Base Idle speed** 600 ± 25 rpm

--

**Curb Idle (target)** 650 ± 50 rpm

--

**Idle Mixture Ratio** 0.4 - 9.4 % CO

--

#### Throttle Position Sensor

T/P Closed 0.15 - 0.85 V  
 T/P Open 3.5 - 4.7 V  
 Idle position voltage 0.15 - 0.85V

--

--

--

#### Radiator Fill

Coolant Type Ethylene Glycol  
 Coolant Capacity 12 3/8 qt

#### Compression Test

Standard 186 psi  
 Minimum 144 psi  
 Diff Between Cyl. 14 psi

--

--

--

--

--

--

--

--

--

--

--

--

#### Fuel System

**Recommended Fuel** 91 Octane or greater

#### Fuel Pump Pressure @ Idle

^ Vacuum applied at fuel pressure regulator  
 34 psi

--

Vacuum released at fuel pressure regulator  
 43 psi

--

**Fuel Pump Ω** 0.2 - 5 Ω

--

**Fuel Injector Ω** 10 - 14 Ω

--

--

--

--

#### Sensors

**Ft/Rr O2 Sen Heaters** 2.3 - 4.3 Ω

--

--

#### Crank Position Sensor

77°F (25°C) 166.5 - 203.5 Ω

--

#### Mass Air Flow Sensor

Supply Volt. 11 - 14V

--

Output Volt 1 - 1.7V

--

#### Mass Air Flow

At Idle 3.0 - 6.0 gm/sec

--

2500 rpm 12.9 - 25.3 gm/sec

--

#### Coolant Temp Sensor Ω

68°F (20°C) 2.1 - 2.9 kΩ

--

122°F (50°C) 0.68 - 1.00 kΩ

--

194°F (90°C) 0.236 - 0.260 kΩ

**IACV-AAC Valve Ω** Approx. 30 Ω

**EGR Temp Sensor Ω**  
32°F (0°C) 0.68 - 1.11 mΩ   
122°F (50°C) 0.09 - 0.12 mΩ   
212°F (100°C) 0.017 - 0.024 mΩ

**Fuel Tank Temp Sensor Ω**  
68°F (20°C) 2.3 - 2.7 kΩ   
122°F (50°C) 0.79 - 0.90 kΩ

**Intake Air Temp Sensor**  
68°F (20°C) 2.1 - 2.9 kΩ   
176°F (80°C) 0.68 - 1.00 kΩ

**Electrical  
Ignition System**

Firing Order 1-8-7-3-6-5-4-2

**Ignition Coil**

Primary Voltage 12V

Primary Ω more than 0Ω

<input type="text"/>	<input type="text"/>	<input type="text"/>	<input type="text"/>
<input type="text"/>	<input type="text"/>	<input type="text"/>	<input type="text"/>

**Battery Specs.**

Type 80D26R

Capacity 12V / 55 AH

Cold Crank Current 582 A

Alternator Type LR1110-707J

Nom. Rated Out 12v / 110 A

Reg. Volt 14.1 - 14.7 V

Hot Output amp More than 34 A/1300 rpm

More than 82 A/2500 rpm

More than 105A/5000rpm

<input type="text"/>
<input type="text"/>
<input type="text"/>
<input type="text"/>

**EPA Mileage Estimate**

(city/highway) 18/23



## PREPARATION

**Make sure that the following parts are in order.**

1. Battery
2. Ignition system
3. Engine oil and coolant levels
4. Fuse
5. ECM harness connector
6. Vacuum hoses
7. Air intake system (Oil filler cap, oil level, etc.)
8. Fuel pressure
9. Engine compression
10. Throttle valve
11. Evaporative emission canister purge control valve.

**Note:**

- On A/C equipped vehicles, turn A/C "Off" for testing.
- Transmission should be in "Park" or "Neutral".
- "CO" probe should be inserted into exhaust approximately 16 inches.
- Turn off headlamps, heater blower, rear defogger, etc.
- Front wheels pointed straight.
- Perform inspection with cooling fans "Off".



# QUICK REFERENCE SPECIFICATIONS



Q45 2000

Quick Reference

A/T

## RE4R03A

Trans Code

52x14

Mark Actual to Confirm

Notes

A/T Fluid Type

Nissan Matic 'D'

Oil Capacity

11 1/8 qt

A/T Cooler Type

Fin Type Structure

### Up-Shift Schedule Range (at normal operating temp.) mph(km/h)

	Half Throttle	Full Throttle		
D <sub>1</sub> → D <sub>2</sub>	27 - 30 (44 - 48)	41 - 43 (66 - 70)	<input type="checkbox"/>	<input type="checkbox"/>
D <sub>2</sub> → D <sub>3</sub>	50 - 53 (80 - 86)	75 - 80 (120 - 128)	<input type="checkbox"/>	<input type="checkbox"/>
D <sub>3</sub> → D <sub>4</sub>	74 - 79 (119 - 127)	114 - 120 (183 - 193)	<input type="checkbox"/>	<input type="checkbox"/>

### Lock-Up Clutch mph(km/h)

	Half Throttle	Lock-up ON	Lock-up OFF		
O/D Sw ON (D4)		83 - 88 (134 - 142)	75 - 80 (120 - 128)	<input type="checkbox"/>	<input type="checkbox"/>
O/D Sw OFF (D3)		57 - 62 (91 - 99)	50 - 55 (81 - 89)	<input type="checkbox"/>	<input type="checkbox"/>
<b>Full Throttle</b>					
O/D Sw ON (D4)		114 - 119 (184 - 192)	111 - 116 (178 - 186)	<input type="checkbox"/>	<input type="checkbox"/>
O/D Sw OFF (D3)		57 - 62 (91 - 99)	53 - 58 (86 - 94)	<input type="checkbox"/>	<input type="checkbox"/>

### Stall Rpm

R, D, 2, 1 position	2,300 - 2,500 rpm	<input type="checkbox"/>
---------------------	-------------------	--------------------------

### Line Pressure psi(kg/cm<sup>2</sup>)

	At Curb Idle	At Stall rpm		
R - Position	87 - 92 (6.1 - 6.5)	210 - 223 (14.8 - 15.7)	<input type="checkbox"/>	<input type="checkbox"/>
D,2,1 - Position	63 - 68 (4.4 - 4.8)	151 - 162 (10.6 - 11.4)	<input type="checkbox"/>	<input type="checkbox"/>

### Shift Solenoids

Gear	Solenoid A	Solenoid B		
1st	ON	ON	<input type="checkbox"/>	<input type="checkbox"/>
2nd	OFF	ON	<input type="checkbox"/>	<input type="checkbox"/>
3rd	OFF	OFF	<input type="checkbox"/>	<input type="checkbox"/>
4th	ON	OFF	<input type="checkbox"/>	<input type="checkbox"/>

### Solenoid Valves

	Resistance	Pin Number	
Shift Solenoid A	20 - 40 Ω	3	<input type="checkbox"/>
Shift Solenoid B	20 - 40 Ω	2	<input type="checkbox"/>
Ovr. Clutch Solenoid	20 - 40 Ω	4	<input type="checkbox"/>
Line Pres. Solenoid	2.5 - 5 Ω	6	<input type="checkbox"/>
T/Conv. Clutch Sol	10 - 20 Ω	7	<input type="checkbox"/>

### ATF Temp Sensor

68° F (20° C)	2.5kΩ	<input type="checkbox"/>
176° F (80° C)	0.3kΩ	<input type="checkbox"/>

### Rev Sensor

500 - 650Ω	<input type="checkbox"/>
------------	--------------------------

### Drop Resistor

11.2 - 12.8Ω	<input type="checkbox"/>
--------------	--------------------------

### Brake Band

Anchor end pin torq.	35 - 52 in lbs.	
Num of return turns	2.5	



## PRECAUTIONS

- Before performing any diagnostic test, vehicle should be driven for approximately 10 minutes to raise transmission to the proper operating temperature of 122° to 176°.
- During stall testing, never hold throttle wide open for more than 5 seconds at a time. Extended stall testing can overheat transmission and cause serious damage.
- Nissan Matic 'D' ATF is the only fluid accepted for warranty, service contracts and goodwill repairs.
- Before performing any internal repairs, thoroughly clean the outside of the transmission case to prevent contamination.
- Use lint free cloth or towels for wiping parts. Common shop towels can leave contaminating fibers on the transmission parts and cause improper transmission operation.
- When servicing the valve body, valves, sleeves, plugs, etc. should slide along the bores in the valve body under their own weight.
- Before assembly, apply a coat of ATF to all internal transmission parts. Use petroleum jelly to protect o-rings and seals, or to hold bearings and washers in place during assembly.

**Important Note:** Nissan Matic 'D' must be used in performing repairs paid by Nissan/Infiniti, such as warranty, service contract, or good-will repairs. There will not be reimbursement for repairs when non-genuine Nissan Matic 'D' is used.



# QUICK REFERENCE SPECIFICATIONS

Q45 2000

Quick Reference

Heater & A/C

## AIR CONDITIONER

Mark Actual to Confirm

Notes

### Compressor

Make Calsonic V-6  
Type Swash Plate (Variable Displacement)

### Compressor Clutch

Disc-to-Pulley Clearance 0.012 - 0.024 in(0.3 - 0.6 mm)

### Refrigerant

Type HFC-134a (R134a)  
Capacity 1.4 - 1.5 lb

### Refrigerant Oil

Type Nissan Type "S" Lub.  
Capacity 6.8 fl oz  
Oil to AddPer  
Evaporator 2.5 oz (75 ml)  
Condenser 2.5 oz (75 ml)  
\*Liquid Tank 0.2 oz (5 ml)  
Large Refrig. Leak 1.0 oz (30 ml)  
Compressor  
(\*Add only if comp. is not replaced.)

### Engine Idle w/A/C On

(in Neutral) More than 700 rpm

### Performance Test

#### Recirculating-to-Discharge Air Temp

Relative Humidity	Recirc. Air Temp. at Blower Assy. Inlet	Discharge Air Temp. at Center Ventilator		
	F° (C°)	F° (C°)		
50 - 60 %	77°(25°)	43 - 49° (6 - 9°)	<input type="checkbox"/>	<input type="checkbox"/>
	86°(30°)	51 - 56° (10 - 14°)	<input type="checkbox"/>	<input type="checkbox"/>
	95°(35°)	60 - 66° (16 - 19°)	<input type="checkbox"/>	<input type="checkbox"/>
60 - 70 %	77°(25°)	49 - 54° (9 - 12°)	<input type="checkbox"/>	<input type="checkbox"/>
	86°(30°)	56 - 63° (14 - 17°)	<input type="checkbox"/>	<input type="checkbox"/>
	95°(35°)	66 - 72° (19 - 22°)	<input type="checkbox"/>	<input type="checkbox"/>

#### Ambient Air Temp-to-Operating Pressure

Air temperature	Relative Humidity 50-70%			
	F° (C°)	High-pres.	Low-pres.	
77°(25°)	158 - 218 psi	28 - 40 psi	<input type="checkbox"/>	<input type="checkbox"/>
86°(30°)	178 - 240 psi	36 - 47 psi	<input type="checkbox"/>	<input type="checkbox"/>
95°(35°)	201 - 267 psi	41 - 55 psi	<input type="checkbox"/>	<input type="checkbox"/>
104°(40°)	228 - 304 psi	50 - 65 psi	<input type="checkbox"/>	<input type="checkbox"/>

#### A/C Drive Belt Deflection

Engine Cold	Used Belt	New Belt	
Deflection Limit	0.51 in(13 mm)		<input type="checkbox"/>
Deflection After Adj.	0.35 - 0.39in(9 - 10mm)	0.31 - 0.35in(8 - 9mm)	<input type="checkbox"/>



## PERFORMANCE TEST CONDITIONS

- Vehicle indoors or in the shade
- Doors closed
- Windows/Hood open
- Temperature on "Max" setting
- Discharge air on "Face Vent"
- Recirculation switch on "Recirc"
- Fan speed on "High"
- A/C switch "On" and verify A/C Clutch engagement
- Engine speed at idle RPM
- Verify heater cock is closed
- Operate the A/C system for 10 minutes before taking measurements

### Precautions:

1. When removing the compressor, store it in the same position as it is mounted in the vehicle. Failure to do so may cause lubricant to enter the low pressure chamber and cause compressor damage.
2. Allow components stored in cool areas to warm to area temperatures before removing seals. This prevents condensation from forming inside A/C components.



# QUICK REFERENCE SPECIFICATIONS

Q45 2000

Quick Reference

Suspension

## WHEEL ALIGNMENT (UNLADEN)

Mark Actual to Confirm

Notes

### Suspension Inspection

#### Ball Joint End Play

Vertical End Play 0 in(0 mm)

#### Front Wheel Bearing

Axial End Play 0.0020 in (0.05 mm) or less

#### Rear Wheel Bearing

Axial End Play 0.0020 in (0.05 mm) or less  
Wheel Runout Max. Lateral / Radial Runout:  
0.012 in (0.3 mm) or less

<input type="text"/>	<input type="text"/>	<input type="text"/>	<input type="text"/>
<input type="text"/>	<input type="text"/>	<input type="text"/>	<input type="text"/>

#### Wheel arch Height (Unladen)

	Front Height (Hf)	Rear Height (Hr)
215/60 R16	28.78 in (731 mm)	28.90 in (734 mm)
225/50 R17	28.43 in (722 mm)	28.46 in (723 mm)

<input type="text"/>	<input type="text"/>
<input type="text"/>	<input type="text"/>

#### Front Wheel Alignment

Toe-in	Range	Nominal
Total toe-in(A-B)	0.04 - 0.12 in(1 - 3 mm)	0.08 in(2 mm)
Total toe-in angle (left + right)	0.07° - 0.27° (4' - 16')	0.17°(10')



#### Front Wheel Turning Angle (full turn)

In/Wheel Range	36.83° - 40.83° (36°50' - 40°50')
In/Wheel Nominal	39.83°(39°50')
Out/Wheel Nominal	32.42°(32°25')

<input type="text"/>
<input type="text"/>
<input type="text"/>

#### Camber

Range	-1.42° - 0.08° (-1°25' - 0°05')
Nominal	-0.67° (-0°40')
Lt/Rt Difference	1.00° (1°) or less

#### Caster

Range	5.67° - 7.17° (5°40' - 7°10')
Nominal	6.42° (6°25')
Lt/Rt Difference	1.00°(1°) or less

#### Kingpin Inclination

Range	12.42° - 13.92° (12°25' - 13°55')
Nominal	13.17° (13°10')

#### Rear Wheel Alignment

Toe-in	Range	Nominal
Total toe-in(A-B)	0.0 - 0.20 in(0 - 5 mm)	0.098 in(2.5 mm)
Total toe-in angle (left + right)	0.00° - 0.47°(0'-28')	0.23° (14')



#### Camber

Range	-0.25° - -1.25° (-0°15' - -1°15')
Nominal	-0.75° (-0°45')

**W/Lug Nut Torque** 72-87 ft/lb (10-12 kg/m)



# QUICK REFERENCE DESCRIPTION

**ASIST**<sup>TM</sup>  
AUTOMOTIVE SERVICE INFORMATION SUPPORT TERMINAL  
COPYRIGHT © NISSAN NORTH AMERICA, INC.

Q45 2000

Quick Reference

Suspension

## PRELIMINARY INSPECTION

- Check tires for wear and proper inflation
- Check wheel runout
- Check front wheel bearings excessive play
- Check front suspension for excessive play
- Check steering linkage for excessive play
- Check struts for leakage and condition
- Check vehicle for proper ride height

## Precautions

1. When installing rubber parts, final tightening must be carried out under unladen conditions with the tires on the ground.
2. Recheck alignment after installing removed suspension components.



# QUICK REFERENCE SPECIFICATIONS

Q45 2000

Quick Reference

Brakes

## BRAKE SYSTEM

Mark Actual to Confirm

Notes

<b>Brake Model Code</b>	<b>Front Disc Brake</b> AD31VB	<b>Rear Disc Brake</b> AD11VB		
<b>Brake Fluid</b>	DOT 3 (Recommended)			
<b>Master Cyl. Bore Dia.</b>	1 in(25.4 mm)		<input type="checkbox"/>	
<b>Cylinder Bore Dia.</b>	1.748 in(44.4 mm)	1.50 in(38.2 mm)		
<b>Brake Pad Dimensions</b>				
Length	5.20 in(132 mm)	3.835 in(97.4 mm)		
Width	2.067 in(52.5 mm)	1.335 in(33.9 mm)		
Thickness	0.433 in(11.0 mm)	0.39 in(10 mm)		
<b>Brake Pad Wear Limit</b>				
Min. Thickness	0.079 in(2.0 mm)	0.079 in(2.0 mm)	<input type="checkbox"/>	<input type="checkbox"/>
<b>Brake Rotor Dimensions</b>				
Outer Diameter	11.65 in(296 mm)	11.50 in(292 mm)		
Standard Thickness	1.10 in(28 mm)	0.63 in(16 mm)		
<b>Brake Rotor Repair/Wear Limits</b>				
Max. Runout	0.0028 in(0.07 mm)	0.0028 in(0.07 mm)	<input type="checkbox"/>	<input type="checkbox"/>
Min. Thickness	1.024 in(26.0 mm)	0.551 in(14 mm)	<input type="checkbox"/>	<input type="checkbox"/>
Max. Thk. Variation	0.0004 in(0.01 mm)	0.0008 in(0.02 mm)	<input type="checkbox"/>	<input type="checkbox"/>
<b>Brake Pedal Dimen.</b>				
Free Height 'H'	7.20 - 7.60 in (183 - 193 mm)		<input type="checkbox"/>	
Depressed Height 'D'	3.74 in(95 mm) or more		<input type="checkbox"/>	
Pedal Free Play 'A'	0.039 - 0.118 in(1.0 - 3.0 mm)		<input type="checkbox"/>	
Switch Clearance 'C'	0.012 - 0.039 in(0.3 - 1.0 mm)		<input type="checkbox"/>	
<b>Brake Booster</b>				
Output Rod Length	0.4045 - 0.4144 in(10.275 - 10.525 mm)		<input type="checkbox"/>	
Clevis Length	Approx. 5.51 in(140 mm)		<input type="checkbox"/>	
<b>Parking Drum Brake</b>				
Inside Diameter	6.77 in(172 mm)		<input type="checkbox"/>	<input type="checkbox"/>
<b>Brake Shoe Dimension</b>				
Length	6.77 in(172.0 mm)		<input type="checkbox"/>	<input type="checkbox"/>
Width	0.984 in(25.0 mm)		<input type="checkbox"/>	<input type="checkbox"/>
Thickness	0.126 in(3.2 mm)		<input type="checkbox"/>	<input type="checkbox"/>
<b>Parking Drum Brake Repair/Wear Limit</b>				
Max Inside Diameter	6.81 in(173.0 mm)		<input type="checkbox"/>	<input type="checkbox"/>
Shoe Minimum Thk.	0.059 in(1.5 mm)		<input type="checkbox"/>	<input type="checkbox"/>
<b>Parking Brake Control</b>				
	Number of Notches 5 - 6		<input type="checkbox"/>	
<b>ABS Wheel Sensor</b>				
Clearance Frt	0.0087- 0.028 in(0.22 - 0.71 mm)		<input type="checkbox"/>	<input type="checkbox"/>
Clearance Rr	0.0134 - 0.0350 in(0.34 - 0.89 mm)		<input type="checkbox"/>	<input type="checkbox"/>
Resistance	0.9 - 1.1 kΩ		<input type="checkbox"/>	<input type="checkbox"/>
<b>Wheel Lug Nut</b>	72-87 ft lb (10-12 kg-m)			



## PRECAUTIONS

1. Never reuse drained brake fluid.
2. Be careful not to splash brake fluid on painted surfaces.
3. Use clean brake fluid to clean or wash master cylinder wheel cylinders, and disc brake calipers parts.
4. Mineral oils such as gasoline and kerosene should not be used. They can cause damage to rubber parts of the hydraulic system.
5. Use flare nut wrench when removing or installing brake line fittings.
6. Always torque brake lines.
7. Always replace brake pad shims when replacing brake pads.

### Warning:

Clean brake pads and shoes with a dust collector to minimize the hazard of airborne particles or other materials.



# QUICK REFERENCE SPECIFICATIONS

Q45 2000

Quick Reference

Electrical

## ELECTRICAL

**Mark Actual to Confirm**

**Notes**

### Wire Color Code

B = Black	BR = Brown
W = White	OR = Orange
R = Red	P = Pink
G = Green	PU = Purple
L = Blue	GY = Gray
Y = Yellow	SB = Sky Blue
LG = Light Green	CH = Dark Brown
DG = Dark Green	

When a wire color is striped, the base color is given first, followed by the stripe color. Example L/W = Blue with white stripe

### Battery specification:

Type	80D26R
Capacity	12 V / 55 AH
Cold cranking current	582 A
Load test at 3 × AH for 15 seconds.	

### Battery charging rates:

Amps	Time
50	1 hour
25	2 hours
10	5 hours
5	10 hours

Do not charge battery over 50 ampere rate.  
 Do not "quick charge" a fully discharged battery.  
 If battery electrolyte temperature rises above 140°F, stop charging.

### Starter:

Type	M2T84671 Mitsubishi Gear reduction type
No-load current	Less than 145 A
No-load RPM	More than 3,300

### Alternator:

Type	LR1100-707J Hitachi
Nominal Rating	12 V / 110 A
Output current A/RPM (with 13.5 V applied)	More Than 34 / 1,300 More Than 82 / 2,500 More Than 105 / 5,000
Regulated Output Voltage	14.1 - 14.7

### Thermal Transmitter (Water Temp. Sensor For Gauge)

<b>Water Temperature</b>	<b>Resistance</b>
140°F (60°C)	Approx. 170 - 210 Ω
212°F (100°C)	Approx. 47 - 53 Ω

**Oil Pressure Switch:**

<b>Oil pressure PSI</b>	<b>Continuity</b>
More Than 20 -29	NO
Less Than 20 - 29	YES

**Bulb Specifications:**

<b>Item</b>	<b>Wattage (12V).</b>
Headlamp High/Low	60/55 (w/o xenon) 53/35 (w /xenon)
Fog Lamp	55
Front Turn Signal/Park	27/8
Rear Turn Signal	21
Stop/Tail Lamp	21/5
Tail Lamp	5
Center Stop Lamp	18
Back-up Lamp	18
License Plate Lamp	5
Front MAP Lamp	8
Rear Personal Lamp	8
Vanity Mirror Lamp	1.4
Step Lamp	2.7
Foot Well Lamp	3.4
Trunk Room Lamp	3.4

**How to perform voltage drop test: See Illustrations**

**Symptom: Dim bulb or no operation**

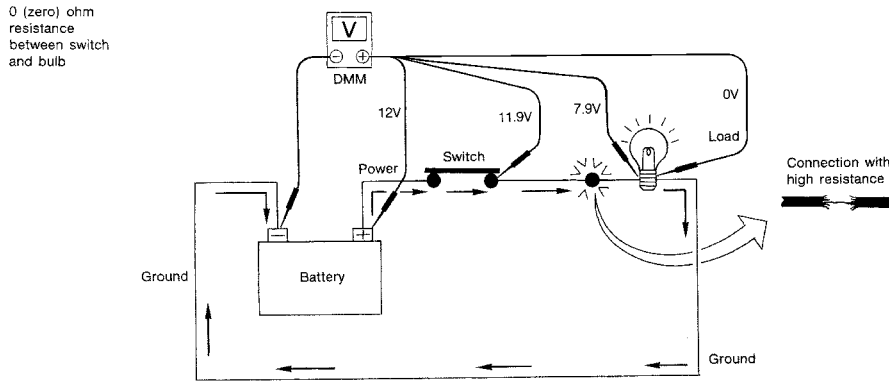

AGI069

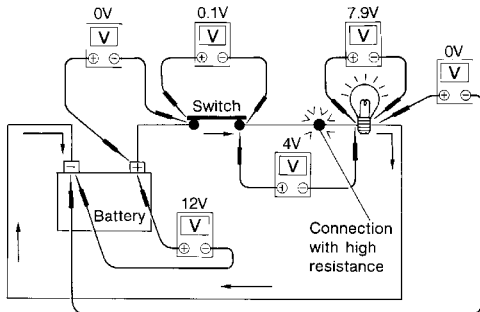

1. Connect the voltmeter as shown, starting at the battery and working your way around the circuit.
2. An unusually large voltage drop will indicate a component or wire that needs to be repaired. In the illustration, the poor connection causes a 4 volt drop.

The chart that follows illustrates some maximum allowable voltage drops. These values are given as a guideline, the exact value for each component may vary.

COMPONENT	VOLTAGE DROP
Wire	negligible <.001 volts
Ground Connections	Approx. 0.1 volts
Switch Contacts	Approx. 0.3 volts

AGI055



## BATTERY CONDITION

### Battery Sulphation:

A battery will be completely discharged if it is left unattended for a long time and the specific gravity becomes less than 1.100. This may result in sulphation on the cell plates. To determine if a battery has been sulfated, note its voltage and current when charging. If low current and higher voltage are observed in the initial stages of charging a sulfated battery is likely. A sulfated battery may sometimes be brought back into service by means of a long slow charge, 12 hours or more.

### Checking Battery Specific Gravity With Hydrometer

Hydrometer temperature correction

Battery electrolyte temp. °C (°F)	Add to specific gravity reading
71 (160)	0.032
66 (150)	0.028
60 (140)	0.024
54 (129)	0.020
49 (120)	0.016
43 (110)	0.012
38 (100)	0.008
32 (90)	0.004
27 (80)	0
21 (70)	-0.004
16 (60)	-0.008
10 (50)	-0.012
4 (39)	-0.016
-1 (30)	-0.020
-7 (20)	-0.024
-12 (10)	-0.028
-18 (0)	-0.032

Corrected specific gravity	Approximate charge condition
1.260 - 1.280	Fully charged
1.230 - 1.250	3/4 charged
1.200 - 1.220	1/2 charged
1.170 - 1.190	1/4 charged
1.140 - 1.160	Almost discharged

- Do not quick charge a fully discharged battery.
- After charging, if the specific gravity of any two cells varies more than .050, the battery should be replaced.

