



2004 Q45 – VK Engine

Mark Actual
To Confirm

Notes

VK45DE

Engine Oil SAE 5W-30 (API SG, SH & Energy Conserving II)
With Oil Filter 5 7/8 qt
Without Oil Filter 5 1/4 qt

Tune up

Spark Plugs (Platinum)

Standard Type	PFR5A-11	<input type="checkbox"/>	<input type="checkbox"/>	<input type="checkbox"/>	<input type="checkbox"/>
Hot Type	PFR4A-11	<input type="checkbox"/>	<input type="checkbox"/>	<input type="checkbox"/>	<input type="checkbox"/>
Cold Type	PFR6A-11	<input type="checkbox"/>	<input type="checkbox"/>	<input type="checkbox"/>	<input type="checkbox"/>

Ignition Timing	12° ± 5° BTDC	<input type="checkbox"/>
Curb Idle (target)	650 ± 50 rpm	<input type="checkbox"/>

Idle Mixture Ratio	0.7 - 9.9 % CO	<input type="checkbox"/>
---------------------------	----------------	--------------------------

Throttle Position Sensor & Accelerator Pedal Position Sensor

T/P Closed	Above 0.36 V	<input type="checkbox"/>
T/P Open	Below 4.75 V	<input type="checkbox"/>

Radiator Fill

Coolant Type Ethylene Glycol
Coolant Capacity 10 3/8 qt with reservoir
7/8 reservoir

Compression Test

Standard	191 psi	<input type="checkbox"/>	<input type="checkbox"/>	<input type="checkbox"/>	<input type="checkbox"/>
Minimum	164 psi	<input type="checkbox"/>	<input type="checkbox"/>	<input type="checkbox"/>	<input type="checkbox"/>
Diff. Between Cyl.	14 psi	<input type="checkbox"/>	<input type="checkbox"/>	<input type="checkbox"/>	<input type="checkbox"/>

Fuel System

Fuel Pump Pressure @ Idle

Approximately 51 psi

Recommended Fuel	91 Octane	<input type="checkbox"/>
Fuel Pump Ω	0.2 - 5.0 Ω	<input type="checkbox"/>
Fuel Injector Ω	13.5 - 17.5 Ω	<input type="checkbox"/>

O2 Sensors

Heated O2 Sensor 1	2.3 - 4.0 Ω	<input type="checkbox"/>	<input type="checkbox"/>
Heated O2 Sensor 2	5.0 - 7.0 Ω	<input type="checkbox"/>	<input type="checkbox"/>

Crankshaft/Camshaft Position Sensor

77°F (25°C) Except 0 or infinite Ω

Mass Air Flow Sensor

Supply Volt.	11 - 14V	<input type="checkbox"/>
Output Volt	1.2 - 1.8V	<input type="checkbox"/>

Throttle Control Motor

77°F (25°C) Approx. 1 - 15 Ω

Mass Air Flow

At Idle	2.0 - 6.0 gm/sec	<input type="checkbox"/>
2500 rpm	7.0 - 20.0 gm/sec	<input type="checkbox"/>

Coolant Temp Sensor Ω

68°F (20°C) 2.1 - 2.9 k Ω
122°F (50°C) 0.68 - 1.00 k Ω
194°F (90°C) 0.236 - 0.260 k Ω

Fuel Tank Temp Sensor Ω

68°F (20°C) 2.3 - 2.7 k Ω
122°F (50°C) 0.79 - 0.90 k Ω

Intake Air Temp Sensor

77°F (25°C) 1.9 - 2.1 k Ω

--

Electrical

Ignition System

Firing Order 1-8-7-3-6-5-4-2

Ignition Coil

Primary Voltage 12V
Primary Ω more than 0 Ω

Battery Specs.

Type 80D23L
Capacity 12V / 52 AH
Cold Crank Current 582 A
Alternator Type A3TG0391
Nom. Rated Out 12V / 110 A
Reg. Volt 14.1 - 14.7 V
Hot Output amp More than 31 A/1300 rpm
More than 90 A/2500 rpm
More than 102 A/5000rpm

--

--

--

--

--

EPA Mileage Estimate

(city/highway) 17/25



2004 Q45 – VK Engine

PREPARATION

Make sure that the following parts are in order.

1. Battery
2. Ignition system
3. Engine oil and coolant levels
4. Fuse
5. ECM harness connector
6. Vacuum hoses
7. Air intake system (Oil filler cap, oil level, etc.)
8. Fuel pressure
9. Engine compression
10. Throttle valve
11. Evaporative emission canister purge control valve.

Note:

- On A/C equipped vehicles, turn A/C "Off" for testing.
- Transmission should be in "Park" or "Neutral".
- "CO" probe should be inserted into exhaust approximately 16 inches.
- Turn off headlamps, heater blower, rear defogger, etc.
- Front wheels pointed straight.
- Perform inspection with cooling fans "Off".



INFINITI

ASIST
AUTOMOTIVE SERVICE INFORMATION SUPPORT TERMINAL

Quick Reference Specifications

NISSAN NORTH AMERICA, INC.
Copyright ©

2004 Q45 – A/T

Mark Actual
To Confirm

Notes

RE5R05A

Trans Code 90x69

A/T Fluid Type Nissan **Matic 'J'** ONLY (P/N 999MP-MTJ00P)

Oil Capacity 10 7/8 qt

A/T Cooler Type Fin Type Structure

A/T Dipstick Tool # J-45475

Up-Shift Schedule Range (at normal operating temp.) mph(km/h)

	Half Throttle	Full Throttle		
D ₁ → D ₂	29 - 31 (22 - 26)	36 - 39 (64 - 68)	<input type="checkbox"/>	<input type="checkbox"/>
D ₂ → D ₃	44 - 49 (59 - 67)	56 - 61 (95 - 103)	<input type="checkbox"/>	<input type="checkbox"/>
D ₃ → D ₄	66 - 73 (100 - 110)	84 - 90 (147 - 157)	<input type="checkbox"/>	<input type="checkbox"/>
D ₄ → D ₅	84 - 90 (153 - 163)	125 - 131 (219 - 229)	<input type="checkbox"/>	<input type="checkbox"/>

Complete Clutch Lock-Up mph(km/h)

	Lock-up ON	Lock-up OFF	
Closed Throttle	35 - 40 (71 - 79)	33 - 38 (53 - 61)	<input type="checkbox"/>
Half Throttle	104 - 109 (191 - 199)	81 - 86 (136 - 144)	<input type="checkbox"/>

Slip Lock-Up

	mph(km/h)	
Closed Throttle	Lock-up ON	Lock-up OFF
3 RD Gear	23 - 28 (27 - 35)	21 - 26 (24 - 32)
4 th Gear	23 - 28 (39 - 47)	21 - 26 (36 - 44)
5 th Gear	27 - 32 (48 - 56)	25 - 30 (45 - 53)

Stall Rpm

R, D, 2, 1 position 2,300 - 2,600 rpm

Line Pressure psi(kg/cm²)

	At Curb Idle	At Stall rpm		
R - Position	57 - 64 (4.0 - 4.5)	247 - 274 (17.3 - 19.3)	<input type="checkbox"/>	<input type="checkbox"/>
D,M - Position	54 - 61 (3.8 - 4.3)	190 - 218 (13.3 - 15.3)	<input type="checkbox"/>	<input type="checkbox"/>

Solenoid Valves

	Resistance	Pin Number	
Line Pressure Sol. Valve	3 - 9 Ω	7	<input type="checkbox"/>
Torque Converter Clutch Sol. Valve	3 - 9 Ω	8	<input type="checkbox"/>
Input Clutch Sol. Valve	3 - 9 Ω	6	<input type="checkbox"/>
High & Low Rev. Clutch Sol. Valve	3 - 9 Ω	3	<input type="checkbox"/>
Front Brake Sol. Valve	3 - 9 Ω	5	<input type="checkbox"/>
Direct Clutch Sol. Valve	3 - 9 Ω	4	<input type="checkbox"/>
Low Coast Brake Sol. Valve	20 - 40 Ω	2	<input type="checkbox"/>

A/T Fluid Temp. Sensor

Condition	ATF Temp Sensor 1	ATF Temp Sensor 2	
32° F (0° C)	2.2 V, 15 kΩ	2.2 V, 10 kΩ	<input type="checkbox"/>
68° F (20° C)	1.8 V, 6.5 kΩ	1.7 V, 4 kΩ	<input type="checkbox"/>
176° F (80° C)	0.6 V, 0.9 kΩ	0.45 V, 0.5 kΩ	<input type="checkbox"/>

Revolution Sensor

Test Condition: Use CONSULT-II pulse frequency measuring function.

Veh. Speed 12 mph in 1st gear, with closed throttle position switch "OFF".

Turbine Rev. Sensor 1 & 2	1.3 kHz	<input type="checkbox"/>
Rev Sensor	185 Hz	<input type="checkbox"/>



2004 Q45 – A/T

PRECAUTIONS

- Before performing any diagnostic test, vehicle should be driven for approximately 10 minutes to raise transmission to the proper operating temperature of 122° to 176°.
- During stall testing, never hold throttle wide open for more than 5 seconds at a time. Extended stall testing can overheat transmission and cause serious damage.
- Nissan **Matic 'J'** ATF is the only fluid accepted for warranty, service contracts and goodwill repairs.
- Before performing any internal repairs, thoroughly clean the outside of the transmission case to prevent contamination.
- Use lint free cloth or towels for wiping parts. Common shop towels can leave contaminating fibers on the transmission parts and cause improper transmission operation.
- When servicing the valve body, valves, sleeves, plugs, etc. should slide along the bores in the valve body under their own weight.
- Before assembly, apply a coat of ATF to all internal transmission parts. Use petroleum jelly to protect o-rings and seals, or to hold bearings and washers in place during assembly.

Important Note: Nissan **Matic 'J'** must be used in performing repairs paid by Infiniti for the 2002 and later Q45, such as warranty, service contract, or good-will repairs. There will not be reimbursement for repairs when non-genuine Nissan **Matic 'J'** is used.



2004 Q45 – Htr & A/C

Mark Actual
To Confirm

Notes

AIR CONDITIONER

Compressor

Make Calsonic Kansei V-6
Type Swash Plate (Variable Displacement)

Compressor Clutch

Disc-to-Pulley Clearance 0.012 - 0.024 in (0.3 - 0.6 mm)

Refrigerant

Type HFC-134a (R134a)
Capacity 1.32 lb (.60 kg)

Refrigerant Oil

Type Nissan Type "S" Lub.
Capacity 6.0 fl oz
Oil to AddPer
Evaporator 2.5 oz (75 ml)
Condenser 1.2 oz (35 ml)
*Liquid Tank 0.3 oz (10 ml)
Large Refrig. Leak 1.0 oz (30 ml)
Compressor
(*Add only if comp. is not replaced.)

Engine Idle w/A/C On

(in Neutral) More than 700 rpm

Performance Test

Recirculating-to-Discharge Air Temp

Relative Humidity	Recirc. Air Temp. at Blower Assy. Inlet	Discharge Air Temp. at Center Ventilator		
	F° (C°)	F° (C°)		
50 - 60 %	77°(25°)	48 - 52° (8.8 - 11.1°)	<input type="text"/>	<input type="text"/>
	86°(30°)	54 - 59° (12.2 - 15.1°)	<input type="text"/>	<input type="text"/>
	95°(35°)	62 - 68° (16.4 - 20.0°)	<input type="text"/>	<input type="text"/>
60 - 70 %	77°(25°)	52 - 56° (11.1 - 13.5°)	<input type="text"/>	<input type="text"/>
	86°(30°)	59 - 64° (15.1 - 18.0°)	<input type="text"/>	<input type="text"/>
	95°(35°)	68 - 74° (20.0 - 23.2°)	<input type="text"/>	<input type="text"/>

Ambient Air Temp-to-Operating Pressure

Air temperature F° (C°)	Relative Humidity 50-70%			
	High-pres.	Low-pres.		
86°(30°)	197.2 - 240.7 psi	30.5 - 39.2 psi	<input type="text"/>	<input type="text"/>
95°(35°)	214.6 - 261.0 psi	36.3 - 46.4 psi	<input type="text"/>	<input type="text"/>
104°(40°)	275.5 - 301.6 psi	43.5 - 52.2 psi	<input type="text"/>	<input type="text"/>



2004 Q45 – Htr & A/C

PERFORMANCE TEST CONDITIONS

- Vehicle indoors or in the shade
- Doors closed
- Windows open
- Hood open
- Temperature on "Max" setting
- Discharge air on "Face Vent"
- Recirculation switch on "Recirc"
- Fan speed on "High"
- A/C switch "On" and verify A/C Clutch engagement
- Engine speed at idle
- Operate the A/C system for 10 minutes before taking measurements

Precautions:

1. When removing the compressor, store it in the same position as it is mounted in the vehicle. Failure to do so may cause lubricant to enter the low pressure chamber and cause compressor damage.
2. Allow components stored in cool areas to warm to area temperatures before removing seals. This prevents condensation from forming inside A/C components.



2004 Q45 – Suspension

Mark Actual
To Confirm

Notes

WHEEL ALIGNMENT (UNLADEN)

Suspension Inspection

Ball Joint End Play

Vertical End Play 0 in (0 mm)

Front Wheel Bearing

Axial End Play 0.0 in (0.0 mm)

--	--

Rear Wheel Bearing

Axial End Play 0.0 in (0.0 mm)
Wheel Runout Max. Lateral / Radial Runout:
0.012 in (0.3 mm) or less

Wheel arch Height (Unladen)

	Front Height (Hf)	Rear Height (Hr)
255/55 R17	28.74 in (730 mm)	27.72 in (704 mm)
225/55 R17 Run Flat	28.90 in (734 mm)	27.83 in (707 mm)
245/55 R18	28.58 in (726 mm)	27.60 in (700 mm)

Front Wheel Alignment

Toe-in	Range	Nominal
Total toe-in	0.08 - 0.0 in (2 - 0 mm)	0.04 in (1 mm)

--

Front Wheel Turning Angle (full turn)

In/Wheel Range	41.75° - 45.75° (41°45' - 45°45')
In/Wheel Nominal	42.75° (42°45')
Out/Wheel Nominal	33.83° (33°50')

Camber

Range	-1.50° - 0.0° (-1°30' - 0°0')
Nominal	-0.75° (-0°45')
Lt/Rt Difference	1.00° (1°) or less

Caster

Range	5.42° - 6.92° (5°25' - 6°55')
Nominal	6.17° (6°10')
Lt/Rt Difference	1.00°(1°) or less

Kingpin Inclination

Range	13.25° - 14.75° (13°15' - 14°45')
Nominal	14.0° (14°0')

--	--

Rear Wheel Alignment

Toe-in	17 in Wheel	18 in Wheel
Total toe-in Range	-0.079 to 0.142 in (-2.0 to 3.6 mm)	-0.063 to 0.157 in (-1.6 to 4.0 mm)
Nominal	0.031 in (0.8 mm)	0.047 in (1.2 mm)

--

Camber

Range	-0.92° to 0.08° (-0°55' to 0°05')	-1.08° to 0.08° (-1°05' to 0°05')
Nominal	-0.42° (-0°25')	-0.58° (-0°35')

--	--

W/Lug Nut Torque 72-87 ft/lb (10-12 kg/m)



2004 Q45 – Suspension

PRELIMINARY INSPECTION

- Check tires for wear and proper inflation
- Check wheel runout
- Check front wheel bearings excessive play
- Check front suspension for excessive play
- Check steering linkage for excessive play
- Check struts for leakage and condition
- Check vehicle for proper ride height

Precautions

1. When installing rubber parts, final tightening must be carried out under unladen conditions with the tires on the ground.
2. Recheck alignment after installing removed suspension components.



2004 Q45 – Brakes

Mark Actual
To Confirm

Notes

BRAKE SYSTEM

Brake Model Code	Front Disc Brake CLZ31VA	Rear Disc Brake AD14VD				
Brake Fluid	DOT 3 (Recommended)					
Master Cyl. Bore Dia.	1 in (25.4 mm)		<input type="text"/>			
Cylinder Bore Dia.	1.687 in (42.86 mm)x2	1.727 in (43.8 mm)				
Brake Pad Dimensions						
Length	5.0 in (127.0 mm)	3.835 in (97.4 mm)	<input type="text"/>			
Width	2.2 in (56.0 mm)	1.335 in (33.9 mm)	<input type="text"/>			
Thickness	0.374 in (9.5 mm)	0.39 in (10.0 mm)	<input type="text"/>			
Brake Pad Wear Limit						
Min. Thickness	0.079 in (2.0 mm)	0.079 in (2.0 mm)	<input type="text"/>	<input type="text"/>	<input type="text"/>	<input type="text"/>
Brake Rotor Dimensions						
Standard Thickness	1.10 in (28 mm)	0.63 in (16 mm)	<input type="text"/>			
Brake Rotor Repair/Wear Limits						
Max. Runout	0.0028 in (0.07 mm)	0.0039 in (0.1 mm)	<input type="text"/>	<input type="text"/>	<input type="text"/>	<input type="text"/>
Min. Thickness	1.024 in (26.0 mm)	0.55 in (14 mm)	<input type="text"/>	<input type="text"/>	<input type="text"/>	<input type="text"/>
Max. Thk. Variation	0.0006 in (0.015 mm)	0.0006 in (0.015 mm)	<input type="text"/>	<input type="text"/>	<input type="text"/>	<input type="text"/>
Brake Pedal Dimen.						
Free Height 'H'	7.57 - 7.97 in (192.4 - 202.4 mm)		<input type="text"/>			
Depressed Height 'D'	3.54 in (90 mm) or more		<input type="text"/>			
Pedal Free Play 'A'	0.12 - 0.43 in (3.0 - 11.0 mm)		<input type="text"/>			
Switch Clearance 'C'	0.0291 - 0.0772 in (0.74 - 1.96 mm)		<input type="text"/>			
Brake Booster	Model M215T					
Input Rod Length	4.92 in (125 mm)		<input type="text"/>			
Parking Drum Brake	DS17HF					
Inside Diameter	6.77 in (172 mm)		<input type="text"/>	<input type="text"/>		
Brake Shoe Dimension						
Thickness	0.126 in (3.2 mm)		<input type="text"/>	<input type="text"/>		
Parking Drum Brake Repair/Wear Limit						
Max Inside Diameter	6.81 in (173.0 mm)		<input type="text"/>	<input type="text"/>		
Shoe Minimum Thk.	0.059 in (1.5 mm)		<input type="text"/>	<input type="text"/>		
Parking Brake Control	Number of Notches 4 - 5		<input type="text"/>			
Wheel Lug Nut	72-87 ft lb (10-12 kg-m)					



2004 Q45 – Brakes

PRECAUTIONS

1. Never reuse drained brake fluid.
2. Be careful not to splash brake fluid on painted surfaces.
3. Use clean brake fluid to clean or wash master cylinder wheel cylinders, and disc brake calipers parts.
4. Mineral oils such as gasoline and kerosene should not be used. They can cause damage to rubber parts of the hydraulic system.
5. Use flare nut wrench when removing or installing brake line fittings.
6. Always torque brake lines.
7. Always replace brake pad shims when replacing brake pads.

Warning:

Clean brake pads and shoes with a dust collector to minimize the hazard of airborne particles or other materials.



2004 Q45 – Electrical

ELECTRICAL

Wire Color Code

B = Black	BR = Brown
W = White	OR = Orange
R = Red	P = Pink
G = Green	PU = Purple
L = Blue	GY = Gray
Y = Yellow	SB = Sky Blue
LG = Light Green	CH = Dark Brown
DG = Dark Green	

When a wire color is striped, the base color is given first, followed by the stripe color. Example L/W = Blue with white stripe

Battery specification:

Type	80D23L
Capacity	12 V / 52 AH
Cold cranking current	582 A
Load test at 3 × AH for 15 seconds.	

Battery charging rates:

Amps	Time
50	1 hour
25	2 hours
10	5 hours
5	10 hours

Do not charge battery over 50 ampere rate.

Do not "quick charge" a fully discharged battery.

If battery electrolyte temperature rises above 140°F, stop charging.

Starter:

Type	M2T85171 Mitsubishi Gear reduction type
No-load current	Less than 145 A
No-load RPM	More than 3,300

Alternator:

Type	A3TG0391 Hitachi
Nominal Rating	12 V / 110 A
Output current A/RPM (with 13.5 V applied)	More Than 31 / 1,300 More Than 90 / 2,500 More Than 102 / 5,000
Regulated Output Voltage	14.1 - 14.7

Oil Pressure Switch:

Oil pressure PSI	Engine Running
More Than 2.8 - 4.26	NO
Less Than 2.8 - 4.26	YES

Bulb Specifications:

Item	Wattage (12V).
Headlamp Low	35 (D2S xenon)
High	55W (H1)
Front Turn Signal/Park	27 (amber)
Rear Turn Signal	21
Stop/Tail Lamp	21/5
Center Stop Lamp	18
Back-up Lamp	18
License Plate Lamp	5
Front MAP Lamp	8
Rear Personal Lamp	8
Vanity Mirror Lamp	1.4
Console Lamp	1.4
Step Lamp	2.7
Trunk Room Lamp	3.4

How to perform voltage drop test: See Illustrations

Symptom: Dim bulb or no operation

0 (zero) ohm resistance between switch and bulb

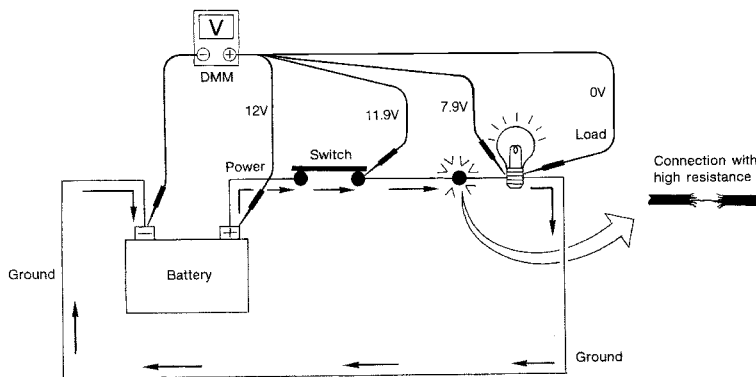

AGI069

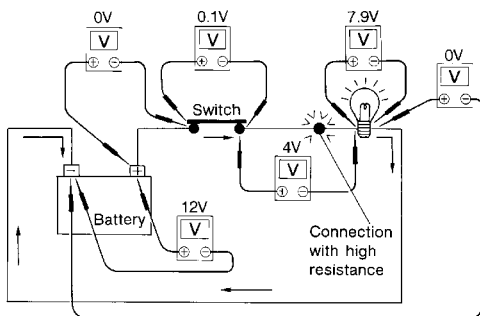

1. Connect the voltmeter as shown, starting at the battery and working your way around the circuit.
2. An unusually large voltage drop will indicate a component or wire that needs to be repaired. In the illustration, the poor connection causes a 4 volt drop.

The chart that follows illustrates some maximum allowable voltage drops. These values are given as a guideline, the exact value for each component may vary.

COMPONENT	VOLTAGE DROP
Wire	negligible <.001 volts
Ground Connections	Approx. 0.1 volts
Switch Contacts	Approx. 0.3 volts

AGI055

2004 Q45 – Electrical

BATTERY CONDITION

Battery Sulphation:

A battery will be completely discharged if it is left unattended for a long time and the specific gravity becomes less than 1.100. This may result in sulphation on the cell plates. To determine if a battery has been sulfated, note its voltage and current when charging. If low current and higher voltage are observed in the initial stages of charging a sulfated battery is likely. A sulfated battery may sometimes be brought back into service by means of a long slow charge, 12 hours or more.

Checking Battery Specific Gravity With Hydrometer

Hydrometer temperature correction

Battery electrolyte temp. °C (°F)	Add to specific gravity reading
71 (160)	0.032
66 (150)	0.028
60 (140)	0.024
54 (129)	0.020
49 (120)	0.016
43 (110)	0.012
38 (100)	0.008
32 (90)	0.004
27 (80)	0
21 (70)	-0.004
16 (60)	-0.008
10 (50)	-0.012
4 (39)	-0.016
-1 (30)	-0.020
-7 (20)	-0.024
-12 (10)	-0.028
-18 (0)	-0.032

Corrected specific gravity	Approximate charge condition
1.260 - 1.280	Fully charged
1.230 - 1.250	3/4 charged
1.200 - 1.220	1/2 charged
1.170 - 1.190	1/4 charged
1.140 - 1.160	Almost discharged

- Do not quick charge a fully discharged battery.
- After charging, if the specific gravity of any two cells varies more than .050, the battery should be replaced.