



QUICK REFERENCE SPECIFICATIONS

Q45 1999

Quick Reference

Engine

VH41DE

Mark Actual to Confirm

Notes

Engine Oil SAE 10W-30 (API SG, SH & Energy Conserving II)
 With Oil Filter 5 5/8 qt
 Without Oil Filter 5 1/4 qt

Tune up

Spark Plugs (Platinum)

Standard Type PFR5G-11

Hot Type PFR4G-11

Cold Type PFR6G-11

Ignition Timing 15° ± 2° BTDC

Base Idle speed 600 ± 25 rpm

Curb Idle (target) 650 ± 50 rpm

<input type="checkbox"/>	<input type="checkbox"/>	<input type="checkbox"/>	<input type="checkbox"/>
<input type="checkbox"/>	<input type="checkbox"/>	<input type="checkbox"/>	<input type="checkbox"/>

<input type="checkbox"/>
<input type="checkbox"/>
<input type="checkbox"/>

Idle Mixture Ratio 0.4 - 9.4 % CO

<input type="checkbox"/>

Throttle Position Sensor

T/P Closed 0.35 - 0.65 V

T/P Open Approx. 4.0 V

Idle position voltage 0.35 - 0.65V

<input type="checkbox"/>
<input type="checkbox"/>
<input type="checkbox"/>

Radiator Fill

Coolant Type Ethylene Glycol

Coolant Capacity 12 3/8 qt

Compression Test

Standard 186 psi

Minimum 144 psi

Diff Between Cyl. 14 psi

<input type="checkbox"/>	<input type="checkbox"/>	<input type="checkbox"/>	<input type="checkbox"/>
<input type="checkbox"/>	<input type="checkbox"/>	<input type="checkbox"/>	<input type="checkbox"/>

Fuel System

Fuel Pump Pressure @ Idle

Vacuum applied at fuel pressure regulator

34 psi

<input type="checkbox"/>

Vacuum released at fuel pressure regulator

43 psi

<input type="checkbox"/>

Recommended Fuel 91 Octane

Fuel Pump Ω 0.2 - 5 Ω

Fuel Injector Ω 10 - 14 Ω

<input type="checkbox"/>	<input type="checkbox"/>	<input type="checkbox"/>	<input type="checkbox"/>
<input type="checkbox"/>	<input type="checkbox"/>	<input type="checkbox"/>	<input type="checkbox"/>

Sensors

Ft/Rr O2 Sen Heaters 2.3 - 4.3 Ω

<input type="checkbox"/>	<input type="checkbox"/>
--------------------------	--------------------------

Crank Position Sensor

77°F (25°C) 166.5 - 203.5 Ω

<input type="checkbox"/>

Mass Air Flow Sensor

Supply Volt. 11 - 14V

Output Volt 1 - 1.7V

<input type="checkbox"/>
<input type="checkbox"/>

Mass Air Flow

At Idle 3.0 - 6.0 gm/sec

2500 rpm 12.9 - 25.3 gm/sec

<input type="checkbox"/>
<input type="checkbox"/>

Coolant Temp Sensor Ω

68°F (20°C) 2.1 - 2.9 k Ω
 122°F (50°C) 0.68 - 1.00 k Ω
 194°F (90°C) 0.236 - 0.260 k Ω

IACV-AAC Valve Ω Approx. 30 Ω

--

EGR Temp Sensor Ω

32°F (0°C) 0.68 - 1.11 m Ω
 122°F (50°C) 0.09 - 0.12 m Ω
 212°F (100°C) 0.017 - 0.024 m Ω

Fuel Tank Temp Sensor Ω

68°F (20°C) 2.3 - 2.7 k Ω
 122°F (50°C) 0.79 - 0.90 k Ω

Intake Air Temp Sensor

68°F (20°C) 2.1 - 2.9 k Ω
 176°F (80°C) 0.68 - 1.00 k Ω

Electrical**Ignition System**

Firing Order 1-8-7-3-6-5-4-2

Ignition Coil

Primary Voltage 12V
 Primary Ω more than 0 Ω

Battery Specs.

Type 80D26R
 Capacity 12V / 55 AH
 Cold Crank Current 582 A
 Alternator Type LR1110-707H
 Nom. Rated Out 12v / 110 A
 Reg. Volt 14.1 - 14.7 V
 Hot Output amp More than 34 A/1300 rpm
 More than 82 A/2500 rpm
 More than 105A/5000rpm

--

EPA Mileage Estimate

(city/highway) 18/23



PREPARATION

Make sure that the following parts are in order.

1. Battery
2. Ignition system
3. Engine oil and coolant levels
4. Fuse
5. ECM harness connector
6. Vacuum hoses
7. Air intake system (Oil filler cap, oil level, etc.)
8. Fuel pressure
9. Engine compression
10. Throttle valve
11. Evaporative emission canister purge control valve.

Note:

- On A/C equipped vehicles, turn A/C "Off" for testing.
- Transmission should be in "Park" or "Neutral".
- "CO" probe should be inserted into exhaust approximately 16 inches.
- Turn off headlamps, heater blower, rear defogger, etc.
- Front wheels pointed straight.
- Perform inspection with cooling fans "Off".



QUICK REFERENCE SPECIFICATIONS

Q45 1999

Quick Reference

A/T

RE4R03A

Trans Code

52x14

Mark Actual
to Confirm

Notes

A/T Fluid Type

Nissan Matic 'D'

Oil Capacity

11 1/8 qt

A/T Cooler Type

Fin Type Structure

Up-Shift Schedule Range (at normal operating temp.) mph(km/h)

	Half Throttle	Full Throttle		
D ₁ → D ₂	27 - 30 (44 - 48)	41 - 43 (66 - 70)	<input type="checkbox"/>	<input type="checkbox"/>
D ₂ → D ₃	50 - 53 (80 - 86)	75 - 80 (120 - 128)	<input type="checkbox"/>	<input type="checkbox"/>
D ₃ → D ₄	74 - 79 (119 - 127)	114 - 120 (183 - 193)	<input type="checkbox"/>	<input type="checkbox"/>

Lock-Up Clutch mph(km/h)

	Half Throttle	Lock-up ON	Lock-up OFF		
O/D Sw ON (D4)		83 - 88 (134 - 142)	75 - 80 (120 - 128)	<input type="checkbox"/>	<input type="checkbox"/>
O/D Sw OFF (D3)		57 - 62 (91 - 99)	50 - 55 (81 - 89)	<input type="checkbox"/>	<input type="checkbox"/>
Full Throttle					
O/D Sw ON (D4)		114 - 119 (184 - 192)	111 - 116 (178 - 186)	<input type="checkbox"/>	<input type="checkbox"/>
O/D Sw OFF (D3)		77 - 80 (124 - 128)	71 - 76 (114 - 122)	<input type="checkbox"/>	<input type="checkbox"/>

Stall Rpm

R, D, 2, 1 position	2,300 - 2,500 rpm	<input type="checkbox"/>
---------------------	-------------------	--------------------------

Line Pressure psi(kg/cm²)

	At Curb Idle	At Stall rpm		
R - Position	87 - 92 (6.1 - 6.5)	210 - 223 (14.8 - 15.7)	<input type="checkbox"/>	<input type="checkbox"/>
D,2,1 - Position	63 - 68 (4.4 - 4.8)	151 - 162 (10.6 - 11.4)	<input type="checkbox"/>	<input type="checkbox"/>

Shift Solenoids

Gear	Solenoid A	Solenoid B		
1st	ON	ON	<input type="checkbox"/>	<input type="checkbox"/>
2nd	OFF	ON	<input type="checkbox"/>	<input type="checkbox"/>
3rd	OFF	OFF	<input type="checkbox"/>	<input type="checkbox"/>
4th	ON	OFF	<input type="checkbox"/>	<input type="checkbox"/>

Solenoid Valves

	Resistance	Pin Number	
Shift Solenoid A	20 - 40 Ω	3	<input type="checkbox"/>
Shift Solenoid B	20 - 40 Ω	2	<input type="checkbox"/>
Ovr. Clutch Solenoid	20 - 40 Ω	4	<input type="checkbox"/>
Line Pres. Solenoid	2.5 - 5 Ω	6	<input type="checkbox"/>
T/Conv. Clutch Sol	10 - 20 Ω	7	<input type="checkbox"/>

ATF Temp Sensor

68° F (20° C)	2.5kΩ	<input type="checkbox"/>
176° F (80° C)	0.3kΩ	<input type="checkbox"/>

Rev Sensor

500 - 650Ω	<input type="checkbox"/>
------------	--------------------------

Drop Resistor

11.2 - 12.8Ω	<input type="checkbox"/>
--------------	--------------------------

Brake Band

Anchor end pin torq.	35 - 52 in lbs.	
Num of return turns	2.5	



PRECAUTIONS

- Before performing any diagnostic test, vehicle should be driven for approximately 10 minutes to raise transmission to the proper operating temperature of 122° to 176°.
- During stall testing, never hold throttle wide open for more than 5 seconds at a time. Extended stall testing can overheat transmission and cause serious damage.
- Nissan Matic 'D' ATF is the only fluid accepted for warranty, service contracts and goodwill repairs.
- Before performing any internal repairs, thoroughly clean the outside of the transmission case to prevent contamination.
- Use lint free cloth or towels for wiping parts. Common shop towels can leave contaminating fibers on the transmission parts and cause improper transmission operation.
- When servicing the valve body, valves, sleeves, plugs, etc. should slide along the bores in the valve body under their own weight.
- Before assembly, apply a coat of ATF to all internal transmission parts. Use petroleum jelly to protect o-rings and seals, or to hold bearings and washers in place during assembly.

Important Note: Nissan Matic 'D' must be used in performing repairs paid by Nissan/Infiniti, such as warranty, service contract, or good-will repairs. There will not be reimbursement for repairs when non-genuine Nissan Matic 'D' is used.



QUICK REFERENCE SPECIFICATIONS

Q45 1999

Quick Reference

Heater & A/C

AIR CONDITIONER

Mark Actual to Confirm

Notes

Compressor

Make Calsonic V-6
Type Swash Plate (Variable Displacement)

Compressor Clutch

Disc-to-Pulley Clearance 0.012 - 0.024 in(0.3 - 0.6 mm)

Refrigerant

Type HFC-134a (R134a)
Capacity 1.4 - 1.5 lb

Refrigerant Oil

Type Nissan Type "S" Lub.
Capacity 6.8 fl oz
Oil to AddPer
Evaporator 2.5 oz (75 ml)
Condenser 2.5 oz (75 ml)
*Liquid Tank 0.2 oz (5 ml)
Large Refrig. Leak 1.0 oz (30 ml)
Compressor
(*Add only if comp. is not replaced.)

Engine Idle w/A/C On

(in Neutral) More than 700 rpm

Performance Test

Recirculating-to-Discharge Air Temp

Relative Humidity	Recirc. Air Temp. at Blower Assy. Inlet	Discharge Air Temp. at Center Ventilator		
	F° (C°)	F° (C°)		
50 - 60 %	77°(25°)	43 - 49° (6 - 9°)	<input type="text"/>	<input type="text"/>
	86°(30°)	51 - 56° (10 - 14°)	<input type="text"/>	<input type="text"/>
	95°(35°)	60 - 66° (16 - 19°)	<input type="text"/>	<input type="text"/>
60 - 70 %	77°(25°)	49 - 54° (9 - 12°)	<input type="text"/>	<input type="text"/>
	86°(30°)	56 - 63° (14 - 17°)	<input type="text"/>	<input type="text"/>
	95°(35°)	66 - 72° (19 - 22°)	<input type="text"/>	<input type="text"/>

Ambient Air Temp-to-Operating Pressure

Air temperature	Relative Humidity 50-70%			
	F° (C°)	High-pres.	Low-pres.	
77°(25°)	158 - 218 psi	28 - 40 psi	<input type="text"/>	<input type="text"/>
86°(30°)	178 - 240 psi	36 - 47 psi	<input type="text"/>	<input type="text"/>
95°(35°)	201 - 267 psi	41 - 55 psi	<input type="text"/>	<input type="text"/>
104°(40°)	228 - 304 psi	50 - 65 psi	<input type="text"/>	<input type="text"/>

A/C Drive Belt Deflection

Engine Cold	Used Belt	New Belt	
Deflection Limit	0.51 in(13 mm)		<input type="text"/>
Deflection After Adj.	0.35 - 0.39in(9 - 10mm)	0.31 - 0.35in(8 - 9mm)	<input type="text"/>



PERFORMANCE TEST CONDITIONS

- Vehicle indoors or in the shade
- Doors closed
- Windows open
- Hood open
- Temperature on "Max" setting
- Discharge air on "Face Vent"
- Recirculation switch on "Recirc"
- Fan speed on "High"
- A/C switch "On" and verify A/C Clutch engagement
- Engine speed at 1500 RPM
- Verify heater cock is closed
- Operate the A/C system for 10 minutes before taking measurements

Precautions:

1. When removing the compressor, store it in the same position as it is mounted in the vehicle. Failure to do so may cause lubricant to enter the low pressure chamber and cause compressor damage.
2. Allow components stored in cool areas to warm to area temperatures before removing seals. This prevents condensation from forming inside A/C components.



QUICK REFERENCE SPECIFICATIONS

Q45 1999

Quick Reference

Suspension

WHEEL ALIGNMENT (UNLADEN)

Mark Actual to Confirm

Notes

Suspension Inspection

Ball Joint End Play

Vertical End Play 0 in(0 mm)

Front Wheel Bearing

Axial End Play 0.0020 in (0.05 mm) or less

Rear Wheel Bearing

Axial End Play 0.0020 in (0.05 mm) or less

Wheel Runout

Max. Lateral / Radial Runout:
0.012 in (0.3 mm)

<input type="text"/>	<input type="text"/>	<input type="text"/>	<input type="text"/>
<input type="text"/>	<input type="text"/>	<input type="text"/>	<input type="text"/>

Wheel arch Height (Unladen)

Front Height (Hf)
28.70 in(729 mm)

Rear Height (Hr)
28.78 in(731 mm)

Front Wheel Alignment

Toe-in

Range

Nominal

Total toe-in(A-B) 0.04 - 0.12 in(1 - 3 mm) 0.08 in(2 mm)

Total toe-in angle (left + right) 0.07° - 0.27° (4' - 16') 0.17°(10')

Front Wheel Turning Angle (full turn)

In/Wheel Range 36.83° - 40.83° (36°50' - 40°50')

In/Wheel Nominal 39.83°(39°50')

Out/Wheel Nominal 32.42°(32°25')

Camber

Range -1.42° - 0.08° (-1°25' - 0°05')

Nominal -0.67° (-0°40')

Lt/Rt Difference 1.00° (1°) or less

Caster

Range 5.67° - 7.17° (5°40' - 7°10')

Nominal 6.42° (6°25')

Lt/Rt Difference 1.00°(1°) or less

Kingpin Inclination

Range 12.42° - 13.92° (12°25' - 13°55')

Nominal 13.17° (13°10')

Rear Wheel Alignment

Toe-in

Range

Nominal

Total toe-in(A-B) 0.0 - 0.20 in(0 - 5 mm) 0.098 in(2.5 mm)

Total toe-in angle (left + right) 0.00°- 0.47°(0'-28') 0.23° (14')

Camber

Range -0.25° - -1.25° (-0°15' - -1°15')

Nominal -0.75° (-0°45')

W/Lug Nut Torque 72-87 ft/lb (10-12 kg/m)



QUICK REFERENCE DESCRIPTION

ASISTTM
AUTOMOTIVE SERVICE INFORMATION SUPPORT TERMINAL
COPYRIGHT © NISSAN NORTH AMERICA, INC.

Q45 1999

Quick Reference

Suspension

PRELIMINARY INSPECTION

- Check tires for wear and proper inflation
- Check wheel runout
- Check front wheel bearings excessive play
- Check front suspension for excessive play
- Check steering linkage for excessive play
- Check struts for leakage and condition
- Check vehicle for proper ride height

Precautions

1. When installing rubber parts, final tightening must be carried out under unladen conditions with the tires on the ground.
2. Recheck alignment after installing removed suspension components.



QUICK REFERENCE SPECIFICATIONS

Q45 1999

Quick Reference

Brakes

BRAKE SYSTEM

Mark Actual to Confirm

Notes

Brake Model Code	Front Disc Brake	Rear Disc Brake				
	AD31VB	AD11VB				
Brake Fluid	DOT 3 (Recommended)					
Master Cyl. Bore Dia.	1 in(25.4 mm)		<input type="checkbox"/>			
Cylinder Bore Dia.	1.748 in(44.4 mm)	1.50 in(38.2 mm)				
Brake Pad Dimensions						
Length	5.20 in(132 mm)	3.835 in(97.4 mm)				
Width	2.067 in(52.5 mm)	1.335 in(33.9 mm)				
Thickness	0.433 in(11.0 mm)	0.39 in(10 mm)				
Brake Pad Wear Limit						
Min. Thickness	0.079 in(2.0 mm)	0.079 in(2.0 mm)	<input type="checkbox"/>	<input type="checkbox"/>	<input type="checkbox"/>	<input type="checkbox"/>
Brake Rotor Dimensions						
Outer Diameter	11.65 in(296 mm)	11.50 in(292 mm)				
Standard Thickness	1.10 in(28 mm)	0.63 in(16 mm)				
Brake Rotor Repair/Wear Limits						
Max. Runout	0.0028 in(0.07 mm)	0.0028 in(0.07 mm)	<input type="checkbox"/>	<input type="checkbox"/>	<input type="checkbox"/>	<input type="checkbox"/>
Min. Thickness	1.024 in(26.0 mm)	0.551 in(14 mm)	<input type="checkbox"/>	<input type="checkbox"/>	<input type="checkbox"/>	<input type="checkbox"/>
Max. Thk. Variation	0.0004 in(0.01 mm)	0.0008 in(0.02 mm)	<input type="checkbox"/>	<input type="checkbox"/>	<input type="checkbox"/>	<input type="checkbox"/>
Brake Pedal Dimen.						
Free Height 'H'	7.20 - 7.60 in (183 - 193 mm)		<input type="checkbox"/>			
Depressed Height 'D'	3.74 in(95 mm) or more		<input type="checkbox"/>			
Pedal Free Play 'A'	0.039 - 0.118 in(1.0 - 3.0 mm)		<input type="checkbox"/>			
Switch Clearance 'C'	0.012 - 0.039 in(0.3 - 1.0 mm)		<input type="checkbox"/>			
Brake Booster						
Output Rod Length	0.4045 - 0.4144 in(10.275 - 10.525 mm)		<input type="checkbox"/>			
Clevis Length	Approx. 5.51 in(140 mm)		<input type="checkbox"/>			
Parking Drum Brake						
Inside Diameter	DS17HE 6.81 in(173 mm)		<input type="checkbox"/>	<input type="checkbox"/>		
Brake Shoe Dimension						
Length	6.77 in(172.0 mm)		<input type="checkbox"/>	<input type="checkbox"/>		
Width	0.984 in(25.0 mm)		<input type="checkbox"/>	<input type="checkbox"/>		
Thickness	0.126 in(3.2 mm)		<input type="checkbox"/>	<input type="checkbox"/>		
Parking Drum Brake Repair/Wear Limit						
Max Inside Diameter	6.81 in(173.0 mm)		<input type="checkbox"/>	<input type="checkbox"/>		
Shoe Minimum Thk.	0.059 in(1.5 mm)		<input type="checkbox"/>	<input type="checkbox"/>		
Parking Brake Control						
	Number of Notches 5 - 6		<input type="checkbox"/>			
ABS Wheel Sensor						
Clearance Frt	0.0087- 0.028 in(0.22 - 0.71 mm)		<input type="checkbox"/>	<input type="checkbox"/>		
Clearance Rr	0.0134 - 0.0350 in(0.34 - 0.89 mm)		<input type="checkbox"/>	<input type="checkbox"/>		
Resistance	0.9 - 1.1 kΩ		<input type="checkbox"/>	<input type="checkbox"/>	<input type="checkbox"/>	<input type="checkbox"/>
Wheel Lug Nut	72-87 ft lb (10-12 kg-m)					



PRECAUTIONS

1. Never reuse drained brake fluid.
2. Be careful not to splash brake fluid on painted surfaces.
3. Use clean brake fluid to clean or wash master cylinder wheel cylinders, and disc brake calipers parts.
4. Mineral oils such as gasoline and kerosene should not be used. They can cause damage to rubber parts of the hydraulic system.
5. Use flare nut wrench when removing or installing brake line fittings.
6. Always torque brake lines.
7. Always replace brake pad shims when replacing brake pads.

Warning:

Clean brake pads and shoes with a dust collector to minimize the hazard of airborne particles or other materials.



QUICK REFERENCE SPECIFICATIONS

Q45 1999

Quick Reference

Electrical

ELECTRICAL

Mark Actual to Confirm

Notes

Wire Color Code

B = Black	BR = Brown
W = White	OR = Orange
R = Red	P = Pink
G = Green	PU = Purple
L = Blue	GY = Gray
Y = Yellow	SB = Sky Blue
LG = Light Green	CH = Dark Brown
DG = Dark Green	

When a wire color is striped, the base color is given first, followed by the stripe color. Example LW = Blue with white stripe

Battery specification:

Type	80D26R
Capacity	12 V / 55 AH
Cold cranking current	582 A
Load test at 3 × AH for 15 seconds.	

Battery charging rates:

Amps	Time
50	1 hour
25	2 hours
10	5 hours
5	10 hours

Do not charge battery over 50 ampere rate.
Do not "quick charge" a fully discharged battery.
If battery electrolyte temperature rises above 140°F, stop charging.

Starter:

Type	M2T84671 Mitsubishi Gear reduction type
No-load current	Less than 145 A
No-load RPM	More than 3,300

Alternator:

Type	LR1100-707H Hitachi
Nominal Rating	12 V / 110 A
Output current A/RPM (with 13.5 V applied)	More Than 34 / 1,300 More Than 82 / 2,500 More Than 105 / 5,000
Regulated Output Voltage	14.1 - 14.7

Thermal Transmitter (Water Temp. Sensor For Gauge)

Water Temperature	Resistance
140°F (60°C)	Approx. 170 - 210 Ω
212°F (100°C)	Approx. 47 - 53 Ω

Oil Pressure Switch:

Oil pressure PSI	Continuity
More Than 20 -29	NO
Less Than 20 - 29	YES

Bulb Specifications:

Item	Wattage (12V).
Headlamp High/Low	60/55 (w/o xenon) 53/35 (w /xenon)
Fog Lamp	55
Front Turn Signal/Park	27/8
Rear Turn Signal	21
Stop/Tail Lamp	21/5
Tail Lamp	5
Center Stop Lamp	18
Back-up Lamp	18
License Plate Lamp	5
Front MAP Lamp	8
Rear Personal Lamp	8
Vanity Mirror Lamp	1.4
Step Lamp	2.7
Foot Well Lamp	3.4
Trunk Room Lamp	3.4

How to perform voltage drop test: See Illustrations

Symptom: Dim bulb or no operation

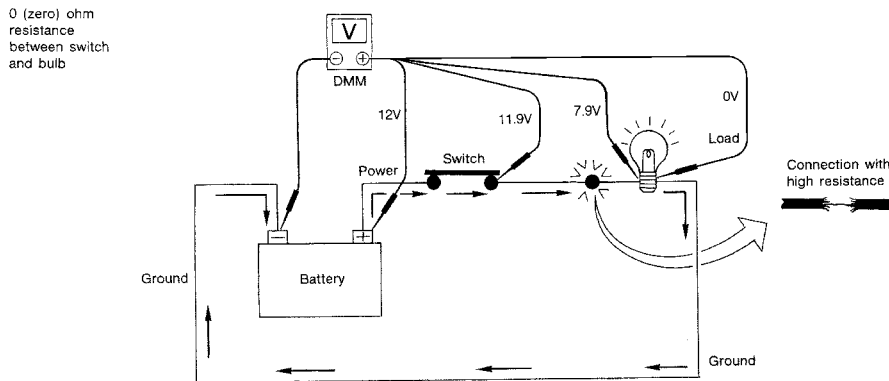

AGI069

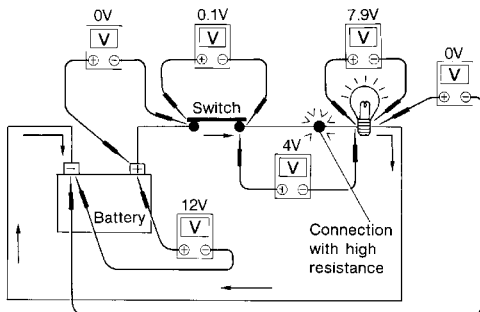

1. Connect the voltmeter as shown, starting at the battery and working your way around the circuit.
2. An unusually large voltage drop will indicate a component or wire that needs to be repaired. In the illustration, the poor connection causes a 4 volt drop.

The chart that follows illustrates some maximum allowable voltage drops. These values are given as a guideline, the exact value for each component may vary.

COMPONENT	VOLTAGE DROP
Wire	negligible <.001 volts
Ground Connections	Approx. 0.1 volts
Switch Contacts	Approx. 0.3 volts

AGI055



BATTERY CONDITION

Battery Sulphation:

A battery will be completely discharged if it is left unattended for a long time and the specific gravity becomes less than 1.100. This may result in sulphation on the cell plates. To determine if a battery has been sulfated, note its voltage and current when charging. If low current and higher voltage are observed in the initial stages of charging a sulfated battery is likely. A sulfated battery may sometimes be brought back into service by means of a long slow charge, 12 hours or more.

Checking Battery Specific Gravity With Hydrometer

Hydrometer temperature correction

Battery electrolyte temp. °C (°F)	Add to specific gravity reading
71 (160)	0.032
66 (150)	0.028
60 (140)	0.024
54 (129)	0.020
49 (120)	0.016
43 (110)	0.012
38 (100)	0.008
32 (90)	0.004
27 (80)	0
21 (70)	-0.004
16 (60)	-0.008
10 (50)	-0.012
4 (39)	-0.016
-1 (30)	-0.020
-7 (20)	-0.024
-12 (10)	-0.028
-18 (0)	-0.032

Corrected specific gravity	Approximate charge condition
1.260 - 1.280	Fully charged
1.230 - 1.250	3/4 charged
1.200 - 1.220	1/2 charged
1.170 - 1.190	1/4 charged
1.140 - 1.160	Almost discharged

- Do not quick charge a fully discharged battery.
- After charging, if the specific gravity of any two cells varies more than .050, the battery should be replaced.

